

EMR Workstation Specifications

The Electronic Medical Record Workstation (EMR) is a housing unit to secure a monitor and CPU so medical records can be entered and stored while helping to comply with HIPAA regulations. These units are typically used in patient or exam rooms in a hospital or other types of medical facilities. The auto-locking feature provides a high level of security for patient info.

CONSTRUCTION

Monitor Compartment

- Constructed primarily of 20 gauge.
- Incorporates a design conducive to airflow and assists with the dispersing of heat from the monitor.
- Can accommodate up to a 24" monitor.
- Gas springs allow the door to self close with minimal assistance.
- Electronic lock provides high level of security and also meets HIPAA regulations.
- Grommets are located on the bottom and both side panels for cable management. Cables can also be run through the back panel of the unit and through the wall.
- Radius front edges add an appealing appearance as well as provide safety in hallways and open areas.
- 100% of all painted steel components are powder coated finish; powder coating is the most environmentally safe coating method available today.

CPU Compartment

- Constructed primarily of 20 gauge.
- Secured via key lock.
- Incorporates a design conducive to airflow and assists with the dispersing of heat from the CPU.
- Grommets are located on the bottom and both side panels for cable management. Cables can also be run through the back panel of the unit and through the wall.
- Door is 100% removable for easy access to CPU for IT personnel.
- Radius front edges add an appealing appearance as well as provide safety in hallways and open areas.
- 100% of all painted steel components are powder coated finish; powder coating is the most environmentally safe coating method available today.

Dimensions

- Exterior Dimensions:
WWP-500E
WWP-500M
WWP-500C

35-15/16"W x 24-9/16"H x 4"D
24-9/16"W x 24-9/16"H x 4"D
11-3/8"W x 24-9/16"H x 4"D

- Interior Dimensions:
Monitor Compartment

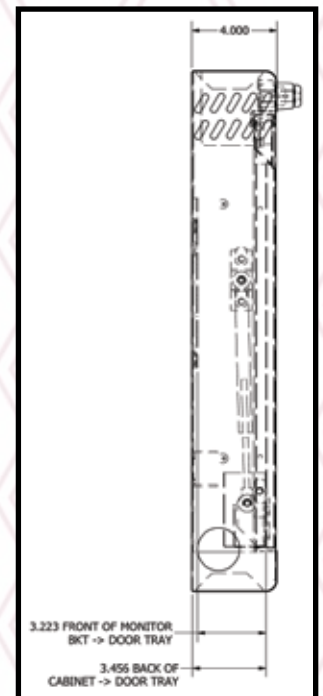
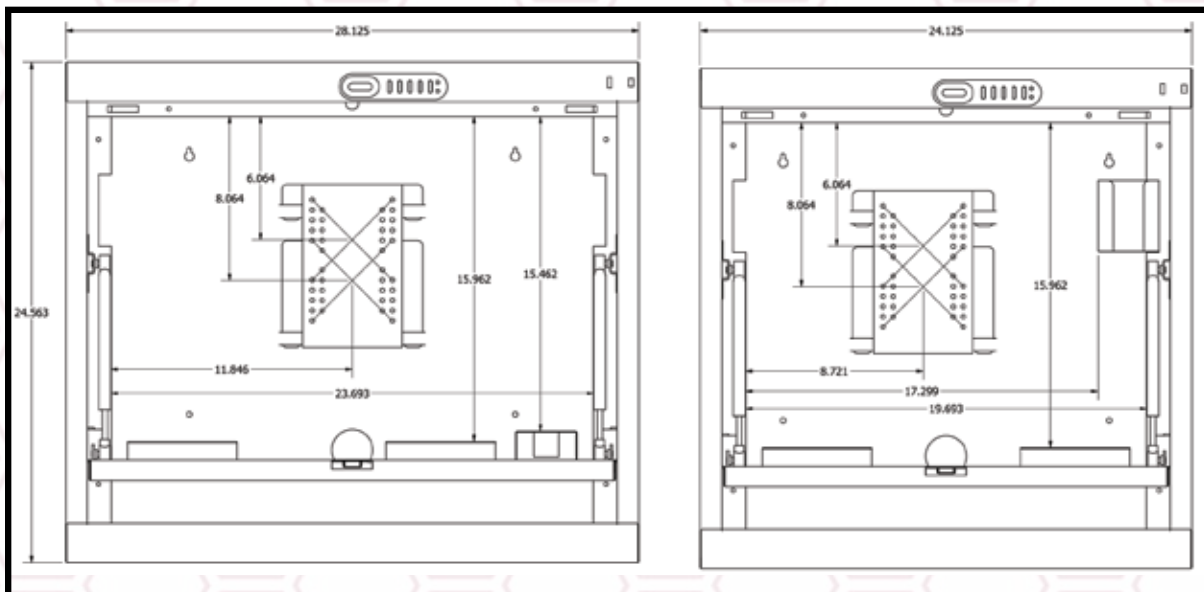

CPU Compartment

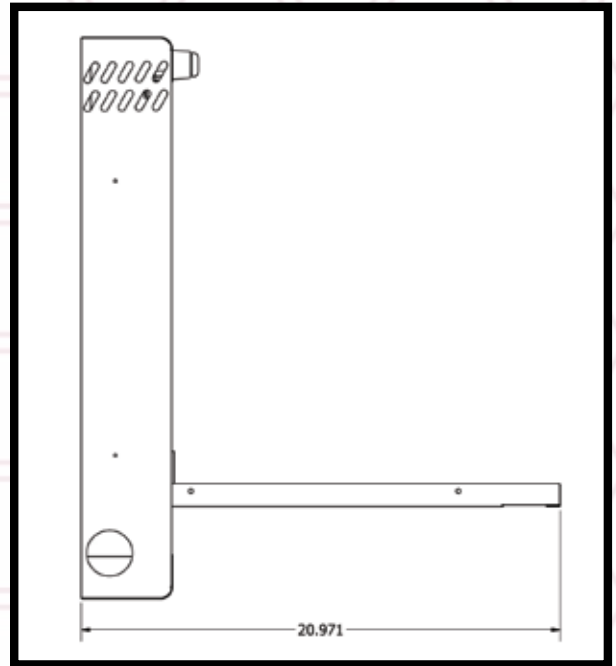
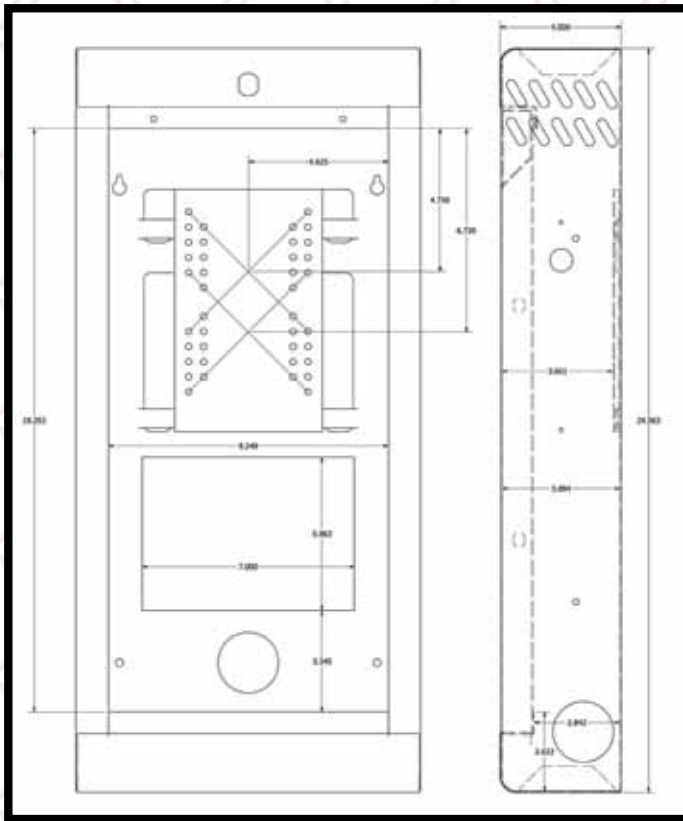

- Total depth of unit including electronic lock 4-3/4"D

Auto Locking Feature/Closing Assist

- After opening the electronic lock, the lock will auto lock after 5 seconds.
- The door can then be folded down to be used as a workstation.
- To close, simply tap on the door and the gas springs will close the door and then it will auto lock.

SHIPPING AND HANDLING

	Est. Product Weights	Est. Shipping Weights
WWP-500E	38 lbs	45 lbs
WWP-500M	30 lbs	37 lbs
WWP-500C	8 lbs	15 lbs

Freight Class

- All EMR's ship Freight Class 70.

Packaging

- All EMR's ship via Fed Ex or Freight depending on the quantity of units. The Monitor and CPU compartments ship assembled but separate to avoid shipping damage.

WARRANTY

Lifetime warranty on parts. Electronic lock carries a 2 year warranty. Warranty details are available upon request.